

Matchplate Vibrators

Multi Use Portable Vibrators

NAVCO® MP series Matchplate Vibrators have a low initial cost and operate at a low air consumption level, which continues to save money through out the life of the vibrator. Special ductile iron castings enable the MP to be machined specifically to withstand high temperatures and prolonged usage.

Benefits:

The MP series, available in an impacting or silent model, delivers a proven high force output for better mold density and smoother finishes. MPs have a steel strike plate and plated pistons for longer life. Equipped with internal springs for horizontal mounting, the MP piston will always bounce back with out sticking.

Options:

Standard mounts include the portable Pin Mount MP with aluminum or steel bracket blocks for quick change and greater mobility and the ST Stud Mount. See Bulletin 1000.115 for more information. An exhaust protector designed specifically for keeping out dust and dampening the noise of the **NAVCO®** Matchplate Vibrator is available as well.

Applications:

Foundry, small hoppers, any unique, small bolt-on, portable requirements.

MP series
with exhaust
protector

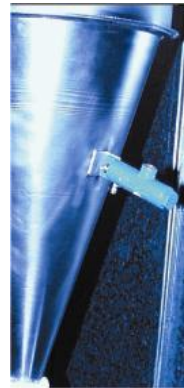
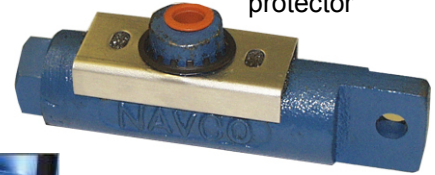

An MP permanently mounted on a small food grade hopper to maintain constant material flow.

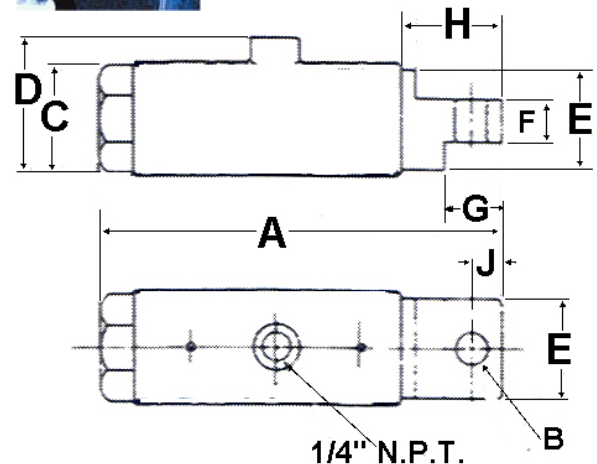

MP series Dimensions

Model	A	B	C	D	E	F	G	H	J	Freq. @ 70 psi	Air Cons. @ 60 psi	Weight
MP 3/4"	5 3/8"	3/8"	1 1/4"	1 3/4"	1"	3/8"	3/4"	1"	1/2"	12,400 VPM	3.0 CFM	1 3/4 lbs.
MP 1"	5 7/8"	1/2"	1 1/2"	2"	1 1/4"	5/8"	1"	1 1/8"	5/8"	10,300 VPM	3.5 CFM	3 1/4 lbs.
MP 1 1/4"	7 5/8"	1/2"	2"	2 1/2"	1 3/4"	3/4"	1 1/2"	1 1/2"	3/4"	8,150 VPM	3.8 CFM	6 1/4 lbs.
MP 2"	10 5/8"	3/4"	2 7/8"	3 3/8"	2 1/2"	3/4"	1 3/4"	1 3/4"	15/16"	5,000 VPM	8.3 CFM	19 lbs.

Handy Portable Vibrator for Foundry and Other Uses

The Problem:

A powder bulk material processing company used a hopper in their processing line that had a screen inside for the purpose of scalping a powder substance before adding it to a mixer. The screen separates clumped material allowing only fine particles to discharge into the mixer. Unfortunately the material would build up on the screen and shut down the process until an operator noticed and banged on the screen to clear it. At this time the operator would also break up or even remove and dispose of large clumps that would not pass the screen.

The Solution:

NAVCO® was contacted to design a solution for maintaining flow through the screen, which would eliminate process interruption.

NAVCO® engineers developed an innovative system that vibrated the screen with out interfering with the material being discharged. The system included an MP 1 SGO, a small portable vibrator, to be mounted outside of the top of the hopper. It was attached to a rod that entered the hopper wall through a dust tight seal. The rod was attached to the screen via a fixture to transfer vibration to the screen. The MP effectively delivers vibration to the screen - dislodging any built up powder and even helping to break up the large clumps that were initially screened out.

Match Plate Portable Vibrator

A Big Screen Cleaning Job for the Small MP

NAVCO's smallest portable vibrator, Model MP



Also available with pin mount and stud mount options.

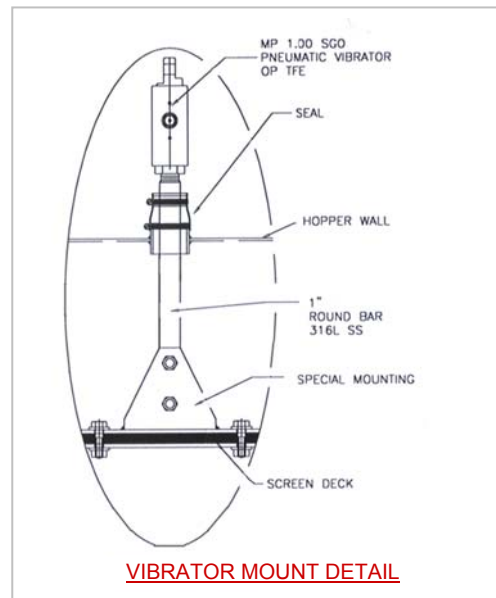
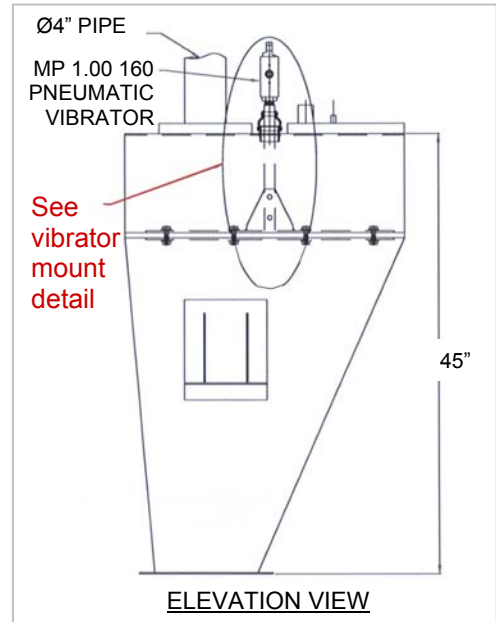
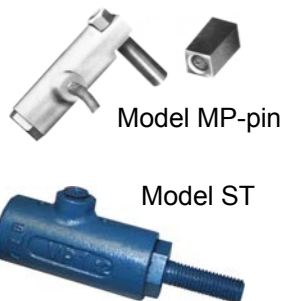

The solution resulted in virtually non-stop production. The MP device successfully keeps the screen clean at all times. Additionally, the large clumps that were previously discarded are now broken down by the vibration, decreasing material waste.